



GARRISON™

For the forward thinking
property owner



For Industrial and Commercial Applications

Swim Centres Car Parks Schools Factories Highways Sports Clubs

GARRISON™ is a classy security fence manufactured from square tubular sections to form a robust barrier. With its horizontal rail at a great distance apart makes this system very difficult to climb.

GARRISON™ is ideal and commonly used around facilities with high visual impact including public facilities, factories and highways.

GARRISON™ will enhance any property adding value with its high level of security and outstanding appearance.

GARRISON™ standard panels can be installed on sloping ground by stepping panels accordingly or alternatively special raked panels can be manufactured on request.

GARRISON™ is a complete modular system which is not only easy to install but also easy to replace panels if necessary without removing posts etc.

SPECIFICATIONS

Panel

Description

GARRISON™ comprises of square tubular pickets with press formed spear tops located through tubular rails.

Finish

Standard finish: Black polyester powder coated after stringent cleaning process.

Dimensions

Height: 1800, 2100mm or 2400mm
Width: 2400mm
Picket: RHS 25 x 25 x 1.2 x 1800, 2100 or 2400mm
Rails: RHS 40 x 40 x 1.6 x 2400

Post

Description

The posts are complete ready to install with metal weather cap.

Finish

Standard finish: Black polyester powder coated after stringent cleaning process.

Dimensions

Length: 2400, 3000 and 3300mm
Size: RHS 65 x 65 x 2.5mm
Post centres: 2470mm

Specification clauses

To be read with Preliminaries/General conditions

Steel tubular security fence/gates

- Manufacturer & Ref: **JAGFENCE SYSTEMS 1800 628 785**
GARRISON™ tubular security fence.
- Height:.....*
- Pickets: 25 x 25 x 1.2 RHS pre galvanised steel with press formed spear top at 140mm centres.
- Rails: 40 x 40 x 1.6 RHS pre galvanised with pickets through rails.
- Post: 65 x 65 x 2.5 RHS pre galvanised with metal weather cap.
- Panel Mount: Cast Aluminium sleeve bracket.
- Coating: all components black polyester powder coated.
- Footings: Set posts in 20 mpa concrete footing 250mm diameter x at least 1/3 the panel height deep.
- Post Centres: 2470mm.
- Fixings: 10g x 15mm tek screws.
- Bottom of fence to be installed 50 - 100mm above ground level.

*See specifications above for available heights.

Other Services

- Gate manufacture (swing and sliding).
- Site deliveries.

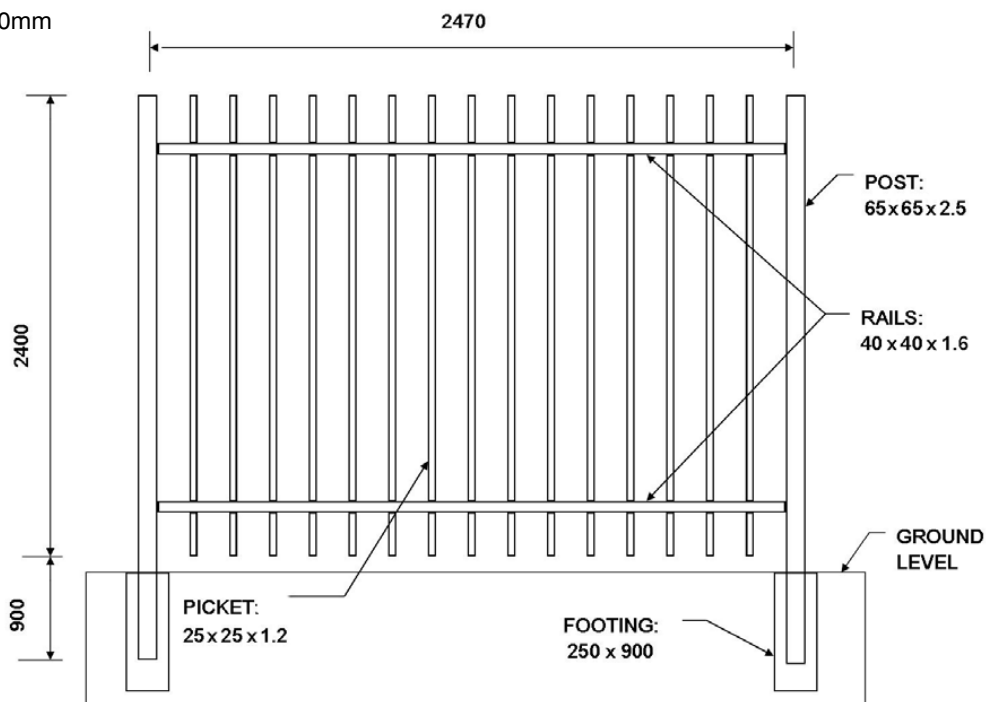

Distributed by:



JAGFENCE SYSTEMS

Phone: 1800 628 785 Fax: 1800 628 795

All information correct at time of going to print. We reserve the right to alter specifications without notice.